

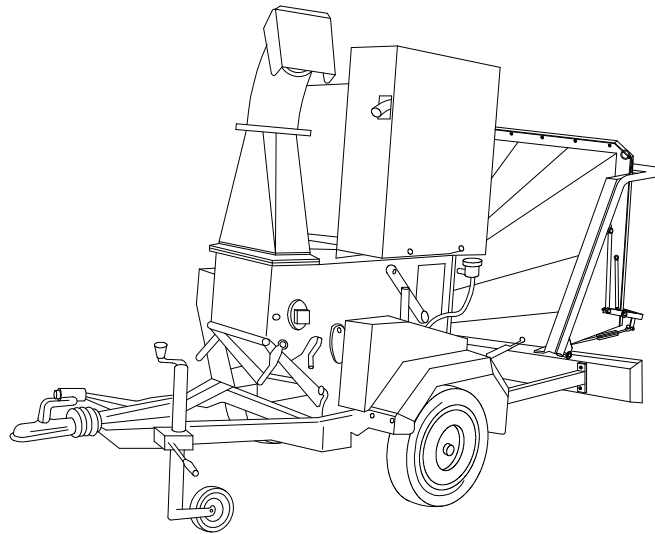

## BIO 300



- Elettrico - Electric 18 HP / 13,3 KW 380 V
- Elettrico - Electric 25 HP / 18 KW 380 V
- Benzina - Petrol 24 HP / 17.8 KW Honda GX 670
- Diesel 27 HP / 20 KW Lombardini FOCS 1003
- Diesel 40 HP / 29 KW Lombardini CHD 1603
- Diesel 37 HP / 27 KW Kubota D 1703
- Trattore Standard / Inversa / In linea - Tractor Standard / Inverse / On line 40÷70 HP
- Rullo idraulico di alimentazione - Hydraulic feed roller
- Rotore a 40 martelli reversibili - Rotor with 40 reversible hammers
- Crivello di raffinazione intercambiabile - Refining and interchangeable screen
- 2 ruote con timone per traino - 2 wheels with drawbar
- Deflettore per scarico a terra - Discharge deflector
- Con tramoggia standard - With standard chute
- Produzione - Production 10÷12 m<sup>3</sup> / h

	Lame N°	C/lame N°	Martelli N°	Ø Triturabile	Ø Cippabile	Peso Kg	Dimensioni cm			Imballo cm		
	-	-	40	10/12	-	750	Lar	Lun	Alt	Lar	Lun	Alt
	No. Blades	No. C/blades	No. Hammers	Ø Triturable	Ø To be cut	Kg Weight	cm Dimensions	cm Packing				
							Bre	Len	Hig	Bre	Len	Hig



Scheda n. B300-01 | Biotrituratore Bio 300

Caravaggi Srl

Via Monte Adamello, 20 - 25037 Pontoglio - BS (ITALY)

Tel. +39 030 7470464 - Fax +39 030 7470004 - Email info@aravaggi.com